

3.5mm Rigid and Semi-Rigid Air Line Connectors

8001 and 8003 Series

Description

Maury 3.5mm 8001 series rigid air line connectors are designed for use with air dielectric coaxial line with 0.0598-inch (1.52mm) inner conductor diameter and 0.1378-inch (3.5mm) outer conductor inner diameter. The 8003 series are used with a 0.141 inch semirigid cable. Materials and instructions for fabricating the air line and cable can be provided as well as a connector tool kit.

These connectors have a high performance 50 ohm, air dielectric interface that operates mode-free through 34 GHz with low VSWR and low insertion loss. They comply with proposed USNC/IEC/SC46D standards: general precision connector, instrument grade – GPC3.5 per Maury data sheet 5E-062, and are mating compatible with SMA and 2.92mm (K) connectors. They are designed for durability and good connection repeatability. Tool kits, torque wrenches and other accessories are available.

Electrical Specifications¹

Frequency Range	DC to 34 GHz
Nominal Impedance	50 ohm
VSWR	1.01 + 0.004f (GHz)
Insertion Loss (dB)	0.015 – f (GHz)
R. F. Leakage	<-100 dB at 26.5 GHz
Contact Resistance:	
Inner Conductor	<2.0 milliohm
Outer Conductor	<0.4 milliohm
Voltage Rating	500 volts RMS
Dielectric Insulation Rating	1500 volts RMS
Power Handling	2.5 kW√f (MHz) above 16 Hz

Environmental Specifications

Thermal Limits	-65° to +85° C
Humidity	20% to 80% RH
Pressure	590mm to 780mm Hg

Typical Performance

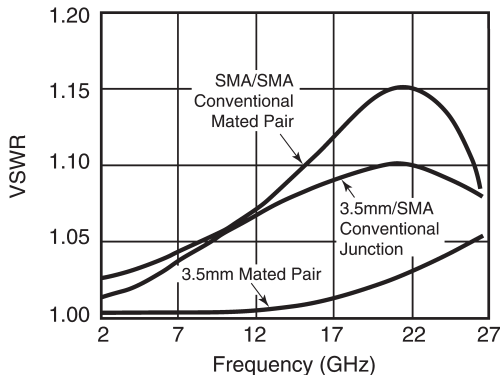

¹ These specifications are for a mated pair (models 8001A and 8001B) and may not apply to when used with mating-compatible connectors.

² 8001K is provided in a foam-lined wood instrument case; 8003K is provided in a foam-lined molded plastic case.

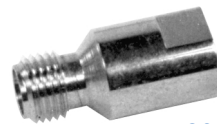

8001A

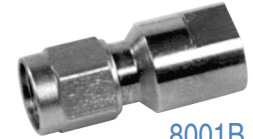

8001B

Dimensions – Inches

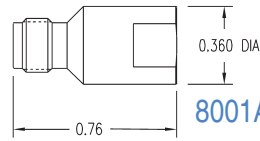

8001A

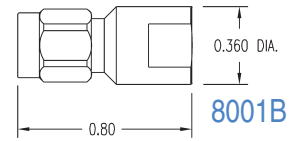

8001B

8001C Female Panel Mount Connector

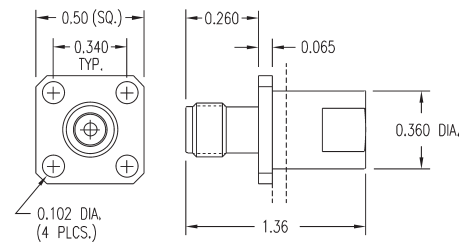

8003A Female Connector for 0.141-inch Semi-Rigid Cable

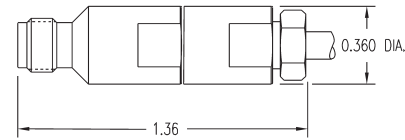

8003B Male Connector for 0.141-inch Semi-Rigid Cable

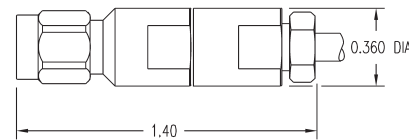

8003C Female Panel Mount Connector for 0.141-inch Semi-Rigid Cable

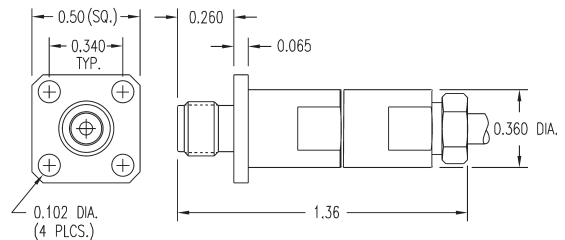

Materials and Tool Kits

MODEL	DESCRIPTION
8001G	Inner conductor rod: unfinished beryllium copper; 0.0589 ± 0.0003-inch dia. 6.00-inch length.
8001H	Outer conductor rod: unfinished gun-drilled, honed aluminum tubing; 0.1378 ± 0.0003-inch I.D.; 0.375-in. O.D.; 6.00-inch length.
8001K ²	Rigid air line connector tool kit: center conductor pin vice & torque pin vice; 3/16-in. open end wrench; 5/16-in. torque wrench
8003K ^{1,2}	Semi-rigid cable connector tool kit: tools and instructions for assembling 0.141-in. semi-rigid cable connectors.

3.5mm Panel Mount, Suspended Stripline, and Micro-Strip Launch Connectors

8002 and 8004 Series

Panel Mount Connectors

The 8002A and 8002B are 3.5mm panel mount connectors in a four-hole mounting configuration. Ordering Option 1 converts these to two-hole mounting. The rear part of the center conductor can be removed for machining and a set of five spare center conductors, 8002C, is available.

8002A Female

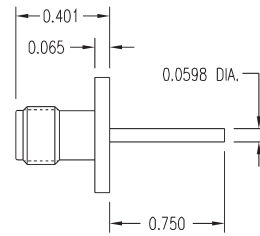

8002B Male

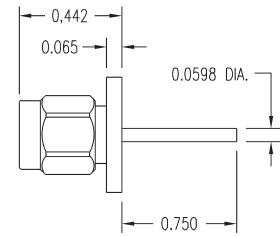

8002D Female

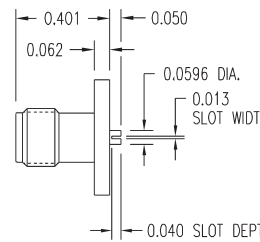

8002E Male

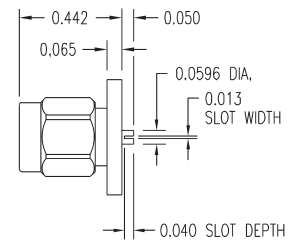

Suspended Stripline Connectors

The 8002D and 8002E are designed for use with suspended stripline circuits utilizing 0.010 thick dielectric with 1/2 ounce copper on both sides (0.012 inch nominal thickness). 8002D and 8002E are provided with the 4-Hole flange configuration only.

Suspended Stripline Connectors

The 8004 series connectors are designed for use with micro-strip circuits and include a transformer from 3.5mm to a 0.01-inch pin diameter launch. Three basic panel mount configurations are available: Mounting Block, Dielectric Feed Thru, and Bushing Feed Thru. Mounting Block and Dielectric Feed Thru versions (8004A, 8004B, 8004C and 8004D) are available in both 4-Hole flange and 2-Hole flange configurations. 8004E and 8004F Bushing Feed Thru versions are only available with the 4-Hole flange.

Mounting Block Configuration

8004A Female

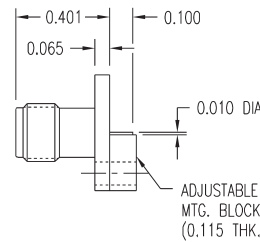

8004B Male

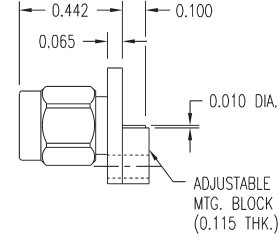

Dielectric Feed Thru Configuration

8004C Female

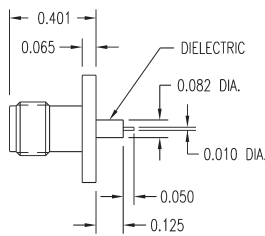

8004D Male

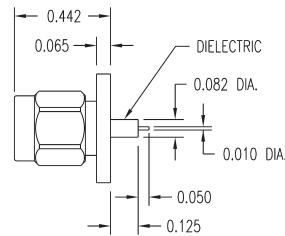

Bushing Feed Thru Configuration

8004E Female

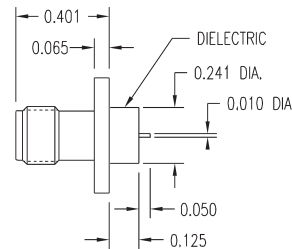

8004F Male

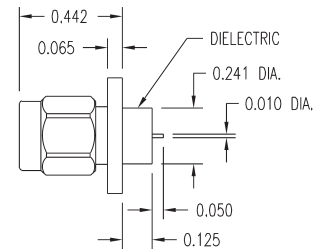

Ordering Flange Configurations

When placing your order be sure to indicate which flange configuration you need. The default configuration is the 4-hole flange, which is standard for all 8002 and 8004 models.

A 2-Hole flange option is available for 8002 and 8004 models except 8002D, 8002E, 8004A, 8004B, 8004E and 8004F. To order connectors with the 2-Hole flange, indicate that you are ordering Option 1 by adding a numeral 1 after the model number.

4-Hole Flange

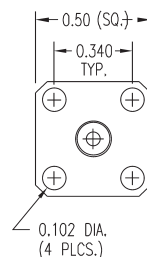

2-Hole Flange (Option 1)

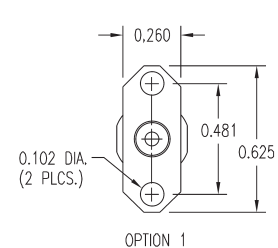

7mm Precision Connectors

2680A1 – Rigid Line Connectors

Description

The 2680A1 is a precision 7mm coaxial connector designed primarily for use with rigid air dielectric transmission lines (principal dimensions: 0.2756/0.01197 in.) and is equivalent to 7mm. These connectors provide superior electrical and mechanical performance for precision laboratory instruments. The sexless coupling mechanism permits any two 7mm connectors to be mated directly. The outer coupling nut can be removed and other coupling mechanisms substituted without disturbing the air line assembly.

The connector barrel configuration complies with IEEE requirements for 7mm general precision connectors. Because electrical and mechanical mating are accomplished in the same plane, the reference plane is clearly defined and permits accurate determination of electrical lengths.

All movable components of the connector are captivated. Assembly instructions with air line preparation dimensions are provided with each connector. The coupling unit is a 3/4" hex fabricated from stainless steel. (See Maury data sheet 5E-060.)



2680A1

Specifications

Frequency Range DC to 18 GHz
 Characteristic Impedance 50 ohm ±0.2%
 VSWR. 1.003 +0.002 (F GHz)
 Insertion Loss (dB) < 1.007 √f (GHz) per pair
 Leakage (up to 6 GHz) Better than 120 dB below signal
 DC Contact Resistance Inner: <1.0 milliohm;
 Outer: <0.1 milliohm

MODEL	DESCRIPTION
2680A1	7mm Sexless

7mm Precision Micro-Strip Connectors

2683 Series

Description

These connectors are designed for mounting on miniature micro-strip packages. They provide a well matched transition from DC to 18 GHz with a typical VSWR of 1.10, with a 50 ohm nominal impedance.

MODEL	DIMENSION "A" (INCHES)
2683A1	0.010 diameter pin
2683B1	0.006 thick x 0.020 wide tab

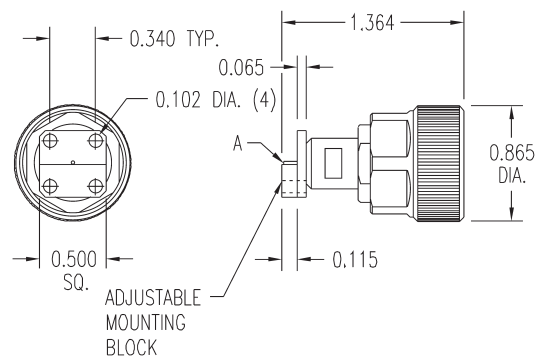

Accessories

Precision connectors require precision assembly and proper gaging of the connector pin depth and location in order to produce optimum performance. The following accessories are the best tools available for doing the job correctly. We highly recommended their use for assembly or disassembly of the Maury precision 7mm connectors on this page.

MODEL	DISCRIPTION
A028	Push-on style 7mm connector gage kit (see page 92)
2697A	Tool kit
2698C2	Torque wrench; 3/4-inch hex; 12 in. lbs (see page 94)

7mm Precision Connectors

2680B1/C1 – Panel Mount Connectors

Description

Two flanged connectors are available. Model 2680C1 has a removable flange and center pin with a 0.093 hole solder pot. Model 2680B1 is essentially a rigid line type connector with an integral flanged body that receives an air line like model 2680A1. Both models exhibit the same basic electrical characteristics as model 2680A1.

MODEL	DESCRIPTION	DIMENSION "A"	
		INCHES	(CM)
2680B1	7mm Sexless with integral flange	1.200	(3.048)
2680C1	7mm Sexless with removable contact pin	0.950	(2.413)

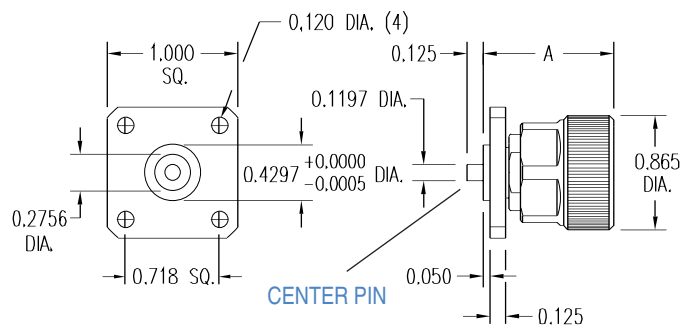

Note: Dimensions shown are for 2680C1 only.

7mm Precision Semi-Rigid Cable Connectors

2681 Series

Description

These connectors are designed for easy assembly with semi-rigid coaxitube cables. The design includes a threaded female bushing that attaches to the cable. This bushing is soldered in place, then threaded into the back of the 7mm connector body.

The 7mm connectors exhibit the same basic electrical characteristics as model 2680A1, and the finished assembly provides a highly stable, highly repeatable connection that is rated for a frequency range from DC to 12.4 GHz, but is usable to 18 GHz.

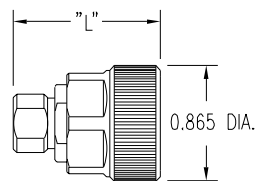

MODEL	FOR USE WITH	MAX. VSWR (DC-12.4 GHz)	LENGTH ("L")	
			INCHES	(CM)
2681C1	0.141 dia. copper coaxitube	1.15	1.5	(3.81)
2681D1	0.250 dia. copper coaxitube	1.12	1.5	(3.81)
2681E1	0.325 dia. copper coaxitube	1.10	1.5	(3.81)

Proper Connector Care

To insure the best electrical performance, prevent serious damage and obtain the most accurate measurements, you must always check the critical interface dimensions of your connectors before mating.

Destructive interference will result if contacts protrude beyond the conductor mating planes. This can cause buckling of the female contact fingers or damage to associated equipment. Excessive gaps between mated contacts or dielectrics can produce undesirable high reflections and reduced power handling. Such out-of-tolerance conditions may result in impaired electrical performance and damage to mated connectors. See page 92 for a complete list of Maury connector gages and gage kits.