

Operating Instructions

Connector Gage Kit

SMA Connectors



General Information

<i>Description</i>	<i>3</i>
<i>Application.....</i>	<i>3</i>
<i>Specifications.....</i>	<i>4</i>

Operation

<i>Visual Inspection.....</i>	<i>8</i>
<i>Cleaning.....</i>	<i>8</i>
<i>Zero Setting.....</i>	<i>8</i>
<i>Gaging SMA Connectors.....</i>	<i>8</i>
<i>Gaging Female Connectors.....</i>	<i>9</i>
<i>Gaging Male Connectors.....</i>	<i>9</i>
<i>Gaging Stepless Male Contact.....</i>	<i>10</i>

Maintenance and Calibration

<i>Maintenance.....</i>	<i>11</i>
<i>Calibration.....</i>	<i>11</i>
<i>Additional Information.....</i>	<i>11</i>
<i>Warranty.....</i>	<i>11</i>
<i>Data Sheets.....</i>	<i>11</i>

General Information

Description

Maury model A027P1, A027A1, A027G1 and A027M1 connector gage kits are designed to measure and check the critical axial interface dimensions of SMA miniature coaxial connectors. **Table 1** lists the connector gage kit models covered by this manual, shows the measurements available using each kit, and which gage and master setting gage to use.

Gage Kit Model Number	FEMALE		MALE		
	Contact Position	Dielectric Position	Stepped Contact Position	Stepless Contact Position	Dielectric Position
A027P1	Yes	—	Yes	—	—
A027A1	Yes	Yes	Yes	—	Yes
A027G1	Yes	Yes	—	—	—
A027M1	—	—	Yes	Yes	Yes
Gage is Marked:	FP	FD	MP	MC	MD
Master Setting Gage to use:	A027T1	A027T1	A027T1 ¹ or A027T2	A027T2	A027T1 ¹ or A027T2
Use End Marked:	F	F	M or MP & MD	MC	M or MP & MD

Table 1. SMA Interface Gaging Compatibility

Application

The critical axial interface dimensions for SMA connectors are shown in **Figure 1**. These dimensions must be maintained in order to provide proper electrical performance and mechanical mating of male and female connectors. SMA connectors are designed to achieve a co-planar mating at the outer conductor mating plane i.e., a metal to metal contact. Destructive interference may result if the contacts protrude beyond the outer conductor mating planes. This can cause buckling of the female contact fingers or damage to associated equipment during mating. Also, an excessive gap of the center contacts when mated produces high reflections and causes breakdown under peak power conditions. The dielectric interface is also critical since protrusion beyond the outer conductor mating plane may prevent proper electrical contact. Excessively recessed dielectrics can introduce unwanted reflections in a mated pair. Connectors on all equipment should be gaged on a routine basis to assure continued performance and prevent damage to other equipment.

¹ A027P1 and A027A1 gage kits are furnished with an A027T1 master setting gage which is marked “M” on one end and “F” on the other. The A027M1 gage kit is furnished with an A027T2 master setting gage which is marked “MC” on one end and “MP and MD” on the other.

These gage kits provide a convenient and accurate means for checking the critical interface dimensions for SMA connectors. The gage assemblies themselves are basically dial indicator comparators and, when zero set, will reflect the actual deviation from zero, which corresponds to deviation from the outer conductor mating plane. A minus (-) reading on the *indicator* represents a recess condition or below the outer conductor mating plane and a plus (+) reading on the *indicator* represents a protrusion or above the outer conductor mating plane.

Specifications

The specifications listed in **Tables 2a** and **2B** are the performance standards based on factory measurements traceable to the U.S.A. National Institute of Standards and Technology (NIST).

To verify that your gage kit is performing to traceable specifications, periodically send the kit to Maury Microwave Corporation for calibration. The recommended calibration cycle is one year. The actual need may vary depending on usage.

Connector Gage Specifications

CHARACTERISTICS	LIMITS	COMMENTS
Gage Resolution	± 0.000100	1/5 Least dial graduation ¹
Gage Calibration Accuracy ⁶	± 0.000750	1 Least dial graduation ² plus 0.000250 measurement guardband
Gage Repeatability ⁴	± 0.000100	1/5 Least dial graduation ²
Master Accuracy	± 0.000050	0.0001 Range ³
Total Uncertainty ^{5, 6}		
RSS	± 0.000765	Root sum of the squares.
Worst Case	± 0.001000	Add resolution, repeatability, gage and master accuracy limits.

Table 2a. All Gages Except MC (Stepless Male Contact)

Connector Gage Specifications

CHARACTERISTICS	LIMITS	COMMENTS
Gage Resolution	± 0.000100	1/5 Least dial graduation ¹
Gage Calibration Accuracy ⁶	± 0.000750	1 Least dial graduation ² plus 0.000250 measurement guardband
Gage Repeatability ⁴	± 0.000100	1/5 Least dial graduation ²
Master Accuracy	± 0.001000	0.002 Range ³
Total Uncertainty ^{5, 6}		
RSS	± 0.001258	Root sum of the squares.
Worst Case	± 0.001950	Add resolution, repeatability, gage and master accuracy limits.

Table 2b. MC Gage Only (Stepless Male Contact)

NOTES:

- ¹ Per ASME B89.1.10M-2001, C5.1.2.
- ² Per ASME B89.1.10M-2001, Table 2.
- ³ Per manufacturer's specification.
- ⁴ Operator skill has a great impact on repeatability. You can easily determine the repeatability of the connector gages by multiple engagements of the master gages following the procedure outlined under **Zero Setting** on page 6.
- ⁵ Performance standards are in compliance with ANSI/NCSL Z540-1, MIL-STD-45662A and ISO 10012-1.
- ⁶ Applies over the operating range for connector gaging +0.035/-0.005" from master gage zero setting.

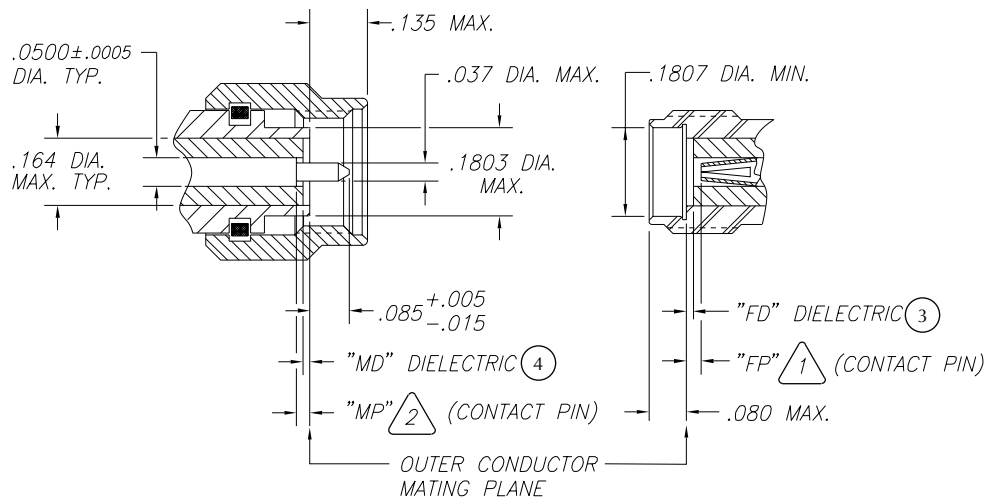

ITEM	SPECIFICATION	FP	FD	MP	MD	COMMENT
A	MIL-C-39012 Class 2	0.000 +0.030 -0.000	-0.002 Maximum	0.000 Minimum	-0.002 Maximum	Per MIL-C-39012/55 and /57
B	MIL-C-39012 Recommended	0.000 +0.010 -0.000	0.000+0.002	0.000 +0.010 -0.000	0.000+0.002	Recommend tolerance for MIL-C-39012 Class 2
C	MIL-C-39012 Standard Test	0.000 +0.003 -0.000	0.000 +0.002 -0.000	0.000 +0.003 -0.000	0.000 +0.002 -0.000	Per MIL-C-39012B Amendment 1
D	MMC Standard	0.000 +0.005 -0.000	0.000+0.002	0.000 +0.005 -0.000	0.000+0.002	Used on most Maury components
E	MMC Precision	0.000 +0.005 -0.000	0.000 +0.002 -0.000	0.000 +0.005 -0.000	0.000 +0.002 -0.000	Supplied on Maury Precision Components
F	Industry Standard	0.000 +0.010 -0.000	0.000 +0.005 -0.002	0.000 +0.010 -0.000	0.000 +0.005 -0.002	OSM 1979 Catalog Page 12

Figure 1. Critical Axial Interface Dimensions of SMA Connectors

Notes

- ① Female contact pin locations — use gage assembly marked “FP” — supplied in A027P1, A027A1, and A027G1 kits.
- ② Male contact pin location — use gage assembly marked “MP” — supplied in A027P1, A027A1 and A027M1 kits.
- ③ Female dielectric interface — use gage assembly marked “FD” supplied in A027A1 and A027G1 kits.
- ④ Male dielectric interface — use gage assembly marked “MD” — supplied in A027A1 and A027M1 kits.
- 5 In reference to the above figure, plus (+) tolerances indicate a recessed condition from the outer conductor mating plane. Minus (-) tolerances indicate a protruding condition above the outer conductor mating plane. *Related to Figure 1.*
- 6 Other dimensions shown in this figure are shown since they affect the mating of the gage assemblies’ gaging mechanisms (bushing and pin). Deviation from these dimensions may cause measurement errors or improper fit between the gaging mechanisms and the connectors being measured. Consult our Customer Service Department on measuring connectors with interface dimensions other than specified above.

A variation of the interface shown in Figure 1 is also commonly used. This variation is shown in Figure 2, where there is no step in the male center contact. Since the center contact does not have a step, the A027P1 and A027A1 kits cannot gage the contact pin location. This can be done with the A027M1 kit. The A027P1 and A027A1 kits can gage the dielectric interface (4).

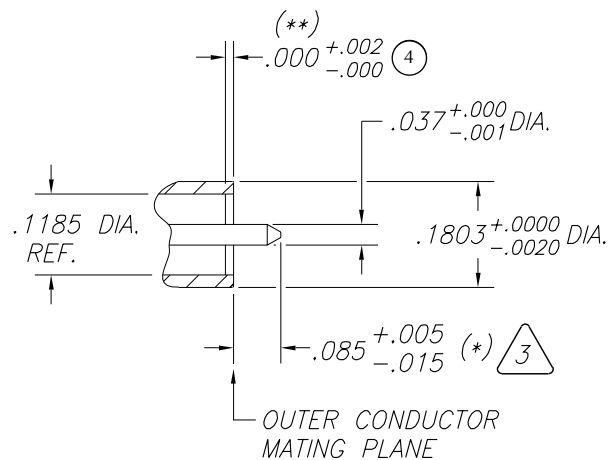

NOTE: The 0.085 dimension can be checked with gage kit A027M1.

Figure 2. SMA Male with Stepless Male Contact

- (*) MIL-C-39012/55 allows more deviation for this dimension; i.e., 0.085.
- (**) MIL-C-39012/55 allows the dielectric to protrude past the other conductor mating plane by 0.002 maximum (+0.002 reading on indicator).

Operation

Visual Inspection

Inspect all connectors carefully before each use. If a connector shows deep scratches, dents, uneven wear, or particles clinging to the mating plane surfaces, clean it and inspect it again. Damaged connectors should be set aside for repair or replacement. Also, try to determine the cause of the damage before making further connections.

Cleaning

Use dry compressed air of a very low velocity first; then a solvent such as isopropyl alcohol. Clean the contacting surfaces using a lint free swab. Then re-inspect the connector to make sure that no fibers have been left around the contact and mating surface.

CAUTION: For optimum measurements *NEVER rotate parts against each other since this will yield faulty readings and could damage the mating surfaces.*

Zero Setting

Each gage kit consists of two or more gage assemblies and a master setting gage. A typical gage assembly is shown in **Figure 3**. The A027T1 master setting gage is shown in **Figure 4** and the A027T2 master gage is shown in **Figure 5**. (See **Table 1** to determine the correct gages to use.)

The gage assemblies are pre-set at our plant for a zero setting, although prior to each use it is good practice to check the gage assembly for zero setting by using the master setting gage. This is accomplished by engaging the gage assembly to the master setting gage. Should resetting of the gage assembly be required, loosen the locking knob and with the master setting gage engaged, rotate the bezel (large knurled ring that rotates the dial face) to zero the pointer, then lock the bezel in place.

Gaging SMA Connectors

The critical mechanical specification in SMA connectors is the recession (setback) of the center conductor relative to the outer conductor mating plane and the dielectric location. No protrusion of the center conductor in front of the outer conductor mating plane is allowable.

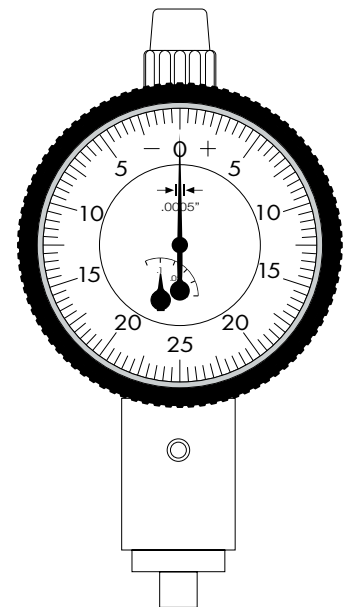

Figure 3. Typical Gage Assembly

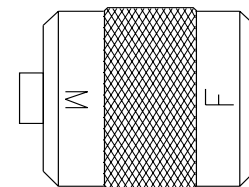

Figure 4. Master Setting Gage P/N A027T1

Gaging Female Connectors (See Table 1 to Determine Correct Gages to Use)

Contact Pin Location: Dimension \triangle in Figure 1.

- Use the gage assembly marked "FP".
- Check the zero setting using the master setting gage end marked "F".
- Carefully engage the female connector to the gage assembly. The gage assembly bushing will slip into the connector and bottom on the outer conductor mating plane.
- The pointer of the dial indicator will then indicate the deviation from zero. A minus (-) reading of the dial shows that the center contact is below the outer conductor mating plane and a plus (+) reading shows that the center contact is protruding past the outer conductor mating plane, which is not acceptable.

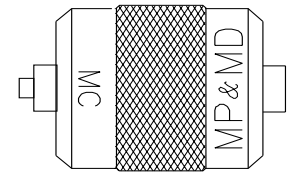

Figure 5. Master Setting Gage P/N A027T2

Dielectric Interface: Dimension $\textcircled{3}$ in Figure 1.

- Use the gage assembly marked "FD".
- Check the zero setting using the master setting gage end marked "F".
- Carefully engage the female SMA connector to the gage assembly. The gage assembly bushing will slip into the SMA connector and bottom on the outer conductor mating plane.
- The pointer of the dial indicator will then indicate the deviation from zero. A minus (-) reading of the dial shows that the dielectric interface is below the outer conductor mating plane and a plus (+) reading shows that the dielectric interface is protruding past the outer conductor mating plane.

Gaging Male Connectors (See Table 1)

Contact Pin Location: Dimension \triangle in Figure 1.

- Use the gage assembly marked "MP".
- Check the zero setting using the master setting gage end marked "M" or "MP and MD".
- Carefully align the center contact pin of the male connector to be gaged so that it will enter the hole in the pin of the gage assembly. Engage straight on until the gage bushing bottoms on the outer conductor mating plane of the male connector.
- The pointer of the dial indicator will then indicate the deviation from zero. A minus (-) reading of the dial shows that the center contact is below the outer conductor mating plane and a plus (+) reading shows that the center contact is protruding past the outer conductor mating plane, which is not acceptable.

Dielectric Interface: Dimension $\textcircled{4}$ in Figure 1.

- Use the gage assembly marked "MD".
- Check the zero setting using the master setting gage end marked "M" or "MP and MD".
- Carefully align the center contact pin of the male SMA connector to be gaged so that it will enter the hole in the pin of the gage assembly. Engage straight on until the gage bushing bottoms on the outer conductor mating plane of the male connector.
- The pointer of the dial indicator will then indicate the deviation from zero. A minus (-) reading of the dial shows that the dielectric interface is below the outer conductor mating plane and a plus (+) reading shows that the dielectric interface is protruding past the outer conductor mating plane.

Gaging Stepless Male Contact (See Table 1 and Figure 2)v

Contact Pin Length: 0.085 dimension \triangle in **Figure 2**.

- a) Use the gage assembly marked "MC".
- b) Check the zero setting using the master gage end marked "MC". This sets the dial indicator zero setting to $0.085 \pm .001$.
- c) Carefully engage the male SMA connector with the gage assembly straight on until the gage bushing bottoms on the outer conductor mating plane of the male connector.
- d) The pointer of the dial indicator will then indicate the deviation from zero, which is nominally 0.085. A minus (-) reading of the dial shows that the center contact is smaller than 0.085 and a plus (+) reading shows that the center contact is greater than 0.085.

For example:

- 1) A -0.010 means the end of the pin is located 0.075 from the outer conductor mating plane. [Note you reverse the sign when you compute, $0.085 + (-0.010) = 0.075$].
- 2) A +0.010 means the end of the pin is located 0.095 from the outer conductor mating plane. [Note when you compute, $0.085 + (+0.010) = 0.095$].

Maintenance and Calibration

Maintenance

These connector gage kits are relatively maintenance free if the components are handled with the same care that is appropriate to all precision equipment. As with any precision component, proper care should be taken to assure clean mating surfaces, proper alignment, and proper torquing. Repair and calibration should be referred to our Customer Service Department.

Calibration

To verify that your calibration kit is performing to traceable specifications, periodically send the kit to Maury Microwave Corporation for calibration. The recommended calibration cycle is one year. The actual need may vary depending on usage.

Should Additional Information or Service be Required, Address Inquiries To:

Maury Microwave Corporation

Attention: Customer Service
2900 Inland Empire Boulevard
Ontario, California 91764-4804
USA

Phone: (909) 987-4715

Email: maury@maurymw.com

Facsimile: (909) 987-1112

Web Site: <http://www.maurymw.com>

Please mention the model number and revision of the software and the date received in any correspondence.

Warranty

We warrant each instrument of our manufacture to be free from defects in material and workmanship. Our obligation under this warranty is limited to servicing or adjusting any instrument returned to our factory for that purpose, and to making good at our factory any part or parts thereof except fuses or batteries. This warranty period is limited to one year from date of shipment to the original purchaser, and to equipment which is returned to us with transportation charges prepaid and which, upon our examination, shall disclose to our satisfaction to have been defective. This warranty does not cover wear from normal usage nor subsequent damage after shipment.

We reserve the right to make changes in design at any time without incurring any obligation to install such changes on units previously sold by us.

This constitutes the only warranty extended by us, and is in lieu of any other obligations or liabilities on our part in connection with the sale of our equipment.