

# 3.5mm Automated Tuners

DATA SHEET / 4T-050G08

MODELS:  
XT983BL01

XT-SERIES TUNERS REPRESENT THE NEXT EVOLUTION IN TUNER TECHNOLOGY. FASTER, MORE ACCURATE, MORE REPEATABLE.

Products covered by one or more  
of the following patents  
9,209,786 / 8,823,392 / 7,589,601 B2



## What is load pull?

Load Pull is the act of presenting a set of controlled impedances to a device under test (DUT) and measuring a set of parameters at each point. By varying the impedance, it is possible to fully characterize the performance of a DUT and use the data to:

- > Verify simulation results of a transistor model (model validation)
- > Gather characterization data for model extraction (behavioral model extraction)
- > Design amplifier matching networks for optimum performance (amplifier design)
- > Ensure a microwave circuit's ability to perform after being exposed to high mismatch conditions (ruggedness test)
- > Confirm the stability or performance of a microwave circuit or consumer product under non-ideal VSWR conditions (stability/performance/conformance/antenna test)

*Example of load pull measurements with Output Power (Pout) contours plotted on a Smith Chart.*

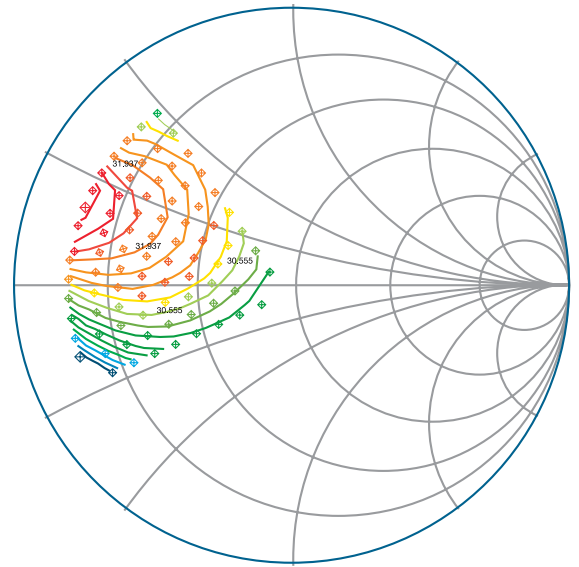

*Iso Pout Contours  
Measured @ 1.85 GHz*

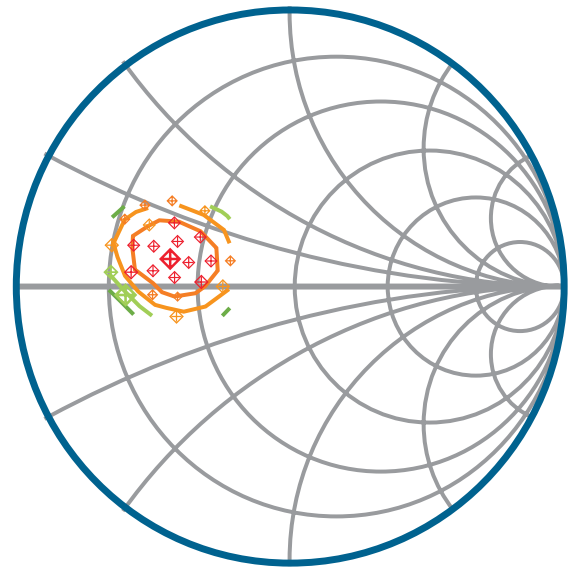

*Iso Pout Contours  
Simulated @ 1.85 GHz*

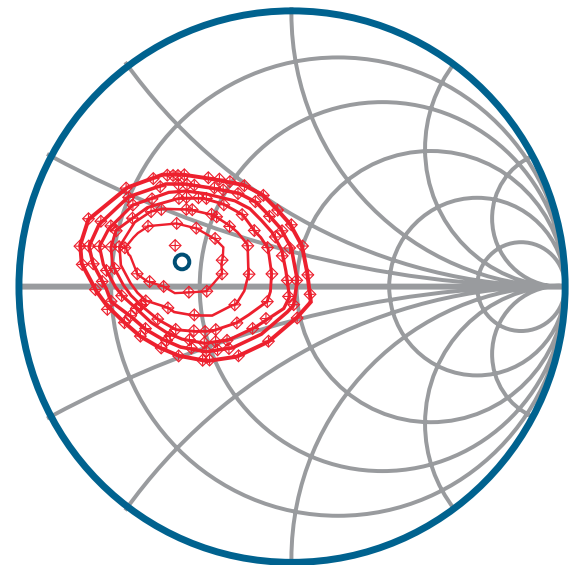

## Slide-Screw Impedance Tuner

One tool available to vary the impedances presented to a DUT is the slide-screw impedance tuner. The slide-screw tuner is based on a  $50\Omega$  slabline and a reflective probe, sometimes referred to as a slug. Ideally, when the probe is fully retracted, the tuner presents a near- $50\Omega$  impedance represented by the center of a normalized Smith Chart. As the probe is lowered into the slabline (Y-direction) it interrupts the electric field that exists between the center conductor and walls of the slabline, reflects some

of the energy back towards the DUT, creates a capacitance and increases the magnitude of reflection (represented by the red curve on the Smith Chart at right). As the probe travels along the slabline (X-direction), the distance between the probe and the DUT is altered, thereby rotating the phase of the reflection (represented by the blue curve on the Smith Chart). It is therefore possible to recreate nearly any arbitrary impedance without the need of discrete components (lumped elements or transmission lines).

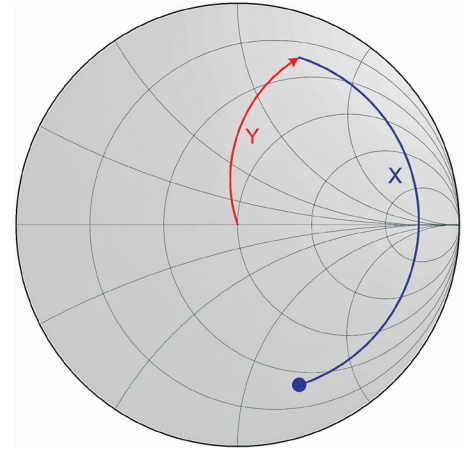

## Simplified representation of a slide-screw tuner.

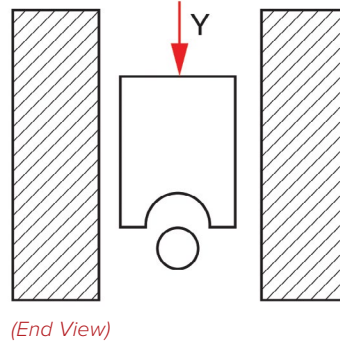
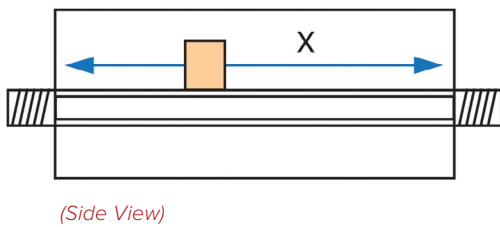

The probes used in slide-screw tuners are wideband in nature, and have similar reflective properties over a wide range of frequencies. In order to increase the overall useful bandwidth of the tuner, two probes of varying dimensions are independently used within a tuner; one for low frequencies and one for high frequencies. In this manner, it is common for slide-screw tuners to achieve an overall frequency range of several octaves to over a decade.

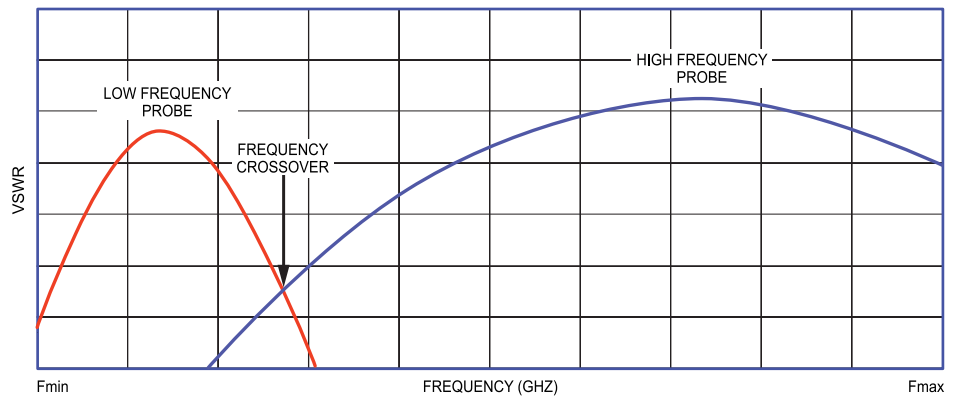

VSWR versus Frequency of a two-probe slide-screw tuner.

## Pre-Calibration (Pre-Characterization)

Slide-screw tuners are available in both manual and automated varieties. While they both work on the same slabline and capacitive probe technique, automated tuners have the ability to be pre-calibrated. Pre-calibration involves recording the s-parameters of each probe at varying X and Y positions for the frequencies of interest using a calibrated vector network analyzer. In general, X and Y positions are selected such that an even distribution of impedances are recorded over the Smith Chart. Once the calibration data is stored in a lookup table, the VNA is no longer required to use the tuner; the tuner 'knows' how to present impedances accurately without VNA verification.

## Tuner Repeatability

Tuner repeatability is defined as the vector difference between the pre-calibrated s-parameter data and subsequent s-parameter measurements after movement, when returning the probe to a given X and Y position. Since the impedances presented to the DUT are reliant on the tuner's ability to accurately return to pre-calibrated states, repeatability is a critical tuner characteristic that affects the reliability of measurement data. In order to guarantee a high level of repeatability, precision

mechanics and motors within the tuner are used to return the probe to its pre-calibrated positions with s-parameter vector differences of  $-40$  to  $-50$ dB or better (see specific tuner model pages 6 through 8 for typical repeatability graphs).

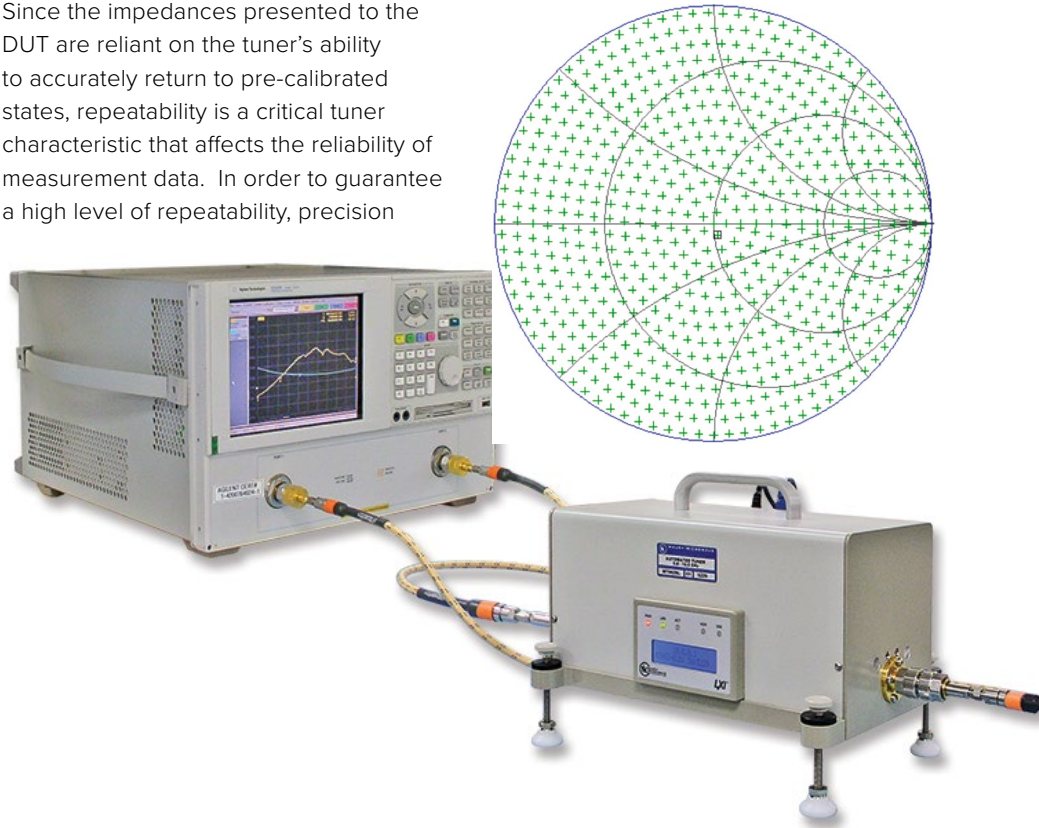

## Tuning Accuracy and Interpolation

During pre-calibration, the tuner's s-parameters are recorded at a user-definable number (normally between 300-3000) of X and Y positions giving an even distribution over the Smith Chart. However, an arbitrary load impedance that falls between pre-calibrated states might be required. To achieve a high level of accuracy, a two-dimensional algorithm is used to interpolate between the closest pre-calibrated impedances

in order to determine the new physical X and Y positions of the desired interpolated impedance. Interpolation increases the number of tunable impedances well beyond the initial pre-calibration range.

Given a sufficiently dense pre-calibration look-up table, a tuner's repeatability (ability to return to pre-calibrated states) and accuracy (ability to interpolate between pre-calibrated states) offer similar performances.

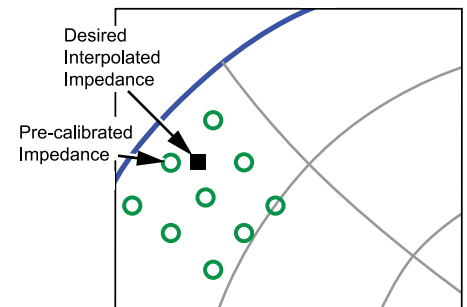

## Patented XT Tuner Technology

(U.S. Patent No. 9,209,786)

## XT Technology

XT-series tuners represent the next evolution in tuner technology. Faster, more accurate, more repeatable.

Upgraded mechanics result in a 5%-20% faster mechanical movement<sup>1</sup>, 10%-35% faster tuner characterization<sup>2</sup> and 10%-15% faster VSWR test<sup>3</sup>.

Linear encoders on the horizontal axis ensure accurate carriage positioning and improve repeatability by 5-10dB<sup>4</sup>.

## High-Speed Profile

Optional High Speed Profile further improves XT tuner speed and results in a 30%-80% faster mechanical movement<sup>1</sup>, 40%-45% faster tuner characterization<sup>2</sup> and 25%-35% faster VSWR test<sup>3</sup>.

HIGH-SPEED PROFILE HAS BEEN OPTIMIZED FOR CONNECTORIZED MEASUREMENTS.

<sup>1</sup> MT983BL01 vs XT983BL01 moving in 1-360 degree steps at 2.45 GHz and 5.5 GHz.

<sup>2</sup> MT983BL01 vs XT983BL01 characterized at 550 points with N5242A PNA-X at 2.45 GHz and 5.5 GHz.

<sup>3</sup> MT983BL01 vs XT983BL01 tuning VSWR circle of 10:1 with 10 degree steps at 2.45 GHz and 5.5 GHz.

<sup>4</sup> MT983BL01 vs XT983BL01; Repeatability defined as re-measuring characterized state.





## Patented Embedded Tuner Controller

(U.S. Patent No. 8,823,392)

All Maury slide-screw automated impedance tuners are equipped with a patented embedded controller (U.S. Patent No. 8,823,392) with onboard microprocessor and memory. After pre-calibration, the lookup table is copied onto the tuner's embedded flash memory storage, as are any s-parameter files of passive components that will be used with the tuner (adapters, cables, fixtures, probes, attenuators...). The tuner's onboard microprocessor will use the lookup table and component s-parameter blocks to calculate the probe positions required to present an arbitrary load impedance taking into account (de-embedding) all adapter/fixture losses

between the tuner and DUT, and all back-side losses between the tuner and the measurement instrument, as well as possible non-50Ω terminations.

Tuner control settings including IP address and firmware upgrade.

Direct ASCII commands can be sent through raw TCP/IP interface over Ethernet or USB and used with any socket programming language or through any Telnet client program in any operating system. Commands include direct impedance tuning, reference-plane shifting, VSWR testing and more.

Parameter	Value
Manufacturer	Maury Microwave Corporation
Instrument Model	MT982-EL30
Serial Number	5270
Firmware Revision	3.4-1.24
Description	Maury MT982-EL30 - 5270
LXI Extended Features	LXI Core Functions
LXI Version	1.4
mDNS-Hostname	169.254.6.77, MT982-EL30-5270.local
IP Address	169.254.6.77
MAC Address	fc:6c:31:00:00:e6
Device Address	TCPIP0::169.254.6.77::5025::SOCKET
Telnet Address	<a href="telnet://169.254.6.77:5024">telnet://169.254.6.77:5024</a>

Parameter	Currently in use
VXI-11 Discovery	On
mDNS Discovery	On
DHCP	On
Auto-IP	On
Network-Hostname	MT982-EL30-5270.local
IP Address	169.254.6.77
Netmask	255.0.0.0
Gateway	0.0.0.0
Dynamic DNS Updates	On
Manual DNS	Off
Domain	Belkin
Primary DNS	10.10.1.17
Secondary DNS	10.10.1.19
Description	Maury MT982-EL30 - 5270
Web Password	hidden

[Edit Configuration](#)

## MTUNE Tuner Characterization and Control Software

### Introduction

MTUNE is a software package that allows device calibration/characterization and control of multiple tuner configurations for automated impedance tuning. It may be used in any application requiring the ability to match the impedance of a microwave circuit element or to establish specific impedances at a terminal interface at various frequencies. The software provides a standalone server (API) for remote communication for advanced use as well as interactive user interface to guide the user through the calibration and tuning process.

### Software Features:

- > Desktop and cloud-based applications enhances user flexibility
- > Modern wizard-driven GUI with support for most commercial VNAs
- > Automatic instrument identification for easy setup
- > Stay up-to-date with software update reminders
- > Enhanced user support with direct ticketing and error logging

### New and Updated Capabilities:

- > Faster multi-frequency tuner characterization
- > New tuner characterization validation process
- > Enhanced frequency interpolation
- > New non-harmonically related multi-frequency impedance tuning

*MTUNE3 is compatible with all MT-series and XT-series tuners with embedded controllers, and can be downloaded from [https://www.maurymw.com/MW\\_RF/MTUNE.php](https://www.maurymw.com/MW_RF/MTUNE.php)*

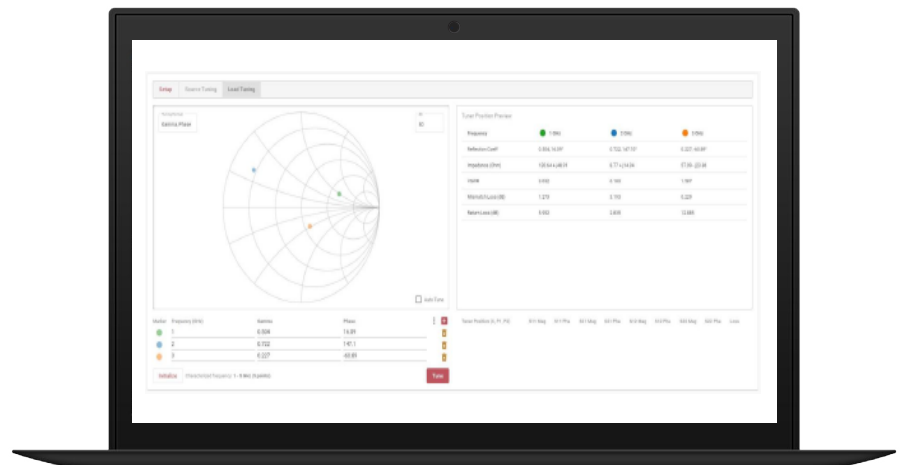

# 3.5mm Automated Tuner

## Available Models

Model	Frequency Range (GHz)	Matching Range		Power Capability <sup>2</sup>	Vector Repeatability (Minimum)	Insertion Loss (Probes Fully Retracted)	Connector Type	Mating Surface Dimensions
		Minimum	Typical <sup>1</sup>					
XT983BL01	2.0 – 26.5	10:1	15:1	25 W CW 250 W PEP	-40 dB	0.6 dB	3.5mm	10.25" [260.4 mm]

<sup>1</sup> Defined as the minimum VSWR over 70% of the frequency range.

<sup>2</sup> Power rated at maximum VSWR.

## Accessories Provided

Each tuner is provided with one (1) MT1020F power supply, one (1) USB cable, one (1) Ethernet cable, one (1) USB to Ethernet adapter, and one (1) operating manual.

## Recommended Accessories

### 8799A1 Torque Wrench

Recommended for tightening all 3.5mm, 2.92mm, 2.4mm & 1.85mm precision connectors to the proper in. lbs without over-torquing the connection.



8799A1

### A050A 2.92mm/3.5mm Digital Connector Gage Kit

Recommended for checking the critical interface dimensions of precision 2.92mm & 3.5mm connectors.



A050A



# Exemplary Performance Data for Model XT983BL01 3.5mm Automated Tuners

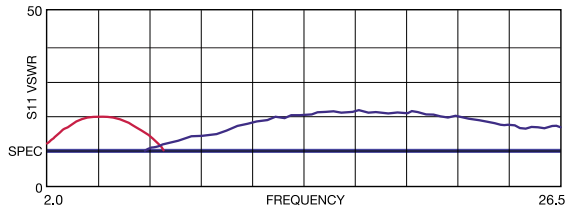

*VSWR versus Frequency for XT983BL01 automated tuners.*

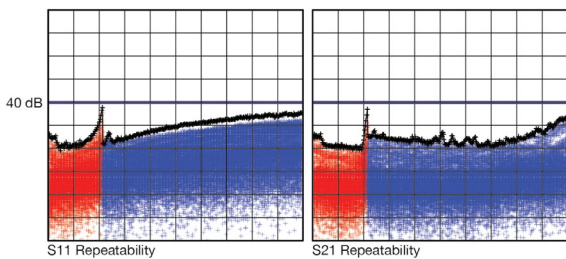

*Repeatability for XT983BL01 automated tuners.*



# XT983 BL01

*Products covered by one or more of the following patents  
9,209,786 / 8,823,392 / 7,589,601 B2*

## Specifications

Frequency Range -- 2.0 to 26.5 GHz  
VSWR Matching Range  
Minimum -- 10:1  
Typical -- 15:1<sup>1</sup>  
Step Size (Probes) -- 7.8 microinches<sup>2</sup>  
Step Size (Carriage) -- 62.5 microinches<sup>2</sup>  
Connectors -- Precision 3.5mm, M/F<sup>3</sup>

Power Capability -- 25 W CW; 250 W PEP<sup>4</sup>  
Vector Repeatability (Min.) -- -40 dB  
Insertion Loss (probes fully retracted) -- 0.6 dB

<sup>1</sup> Defined as the minimum VSWR over 70% of the frequency range.

<sup>2</sup> Based on microstepping (1/16) the drive motors.

<sup>3</sup> Precision 3.5mm per Maury data sheet 5E-062.

<sup>4</sup> Power rated at maximum VSWR.

**XT983BL01**  
**Dimensions in**  
**Inches [mm]**

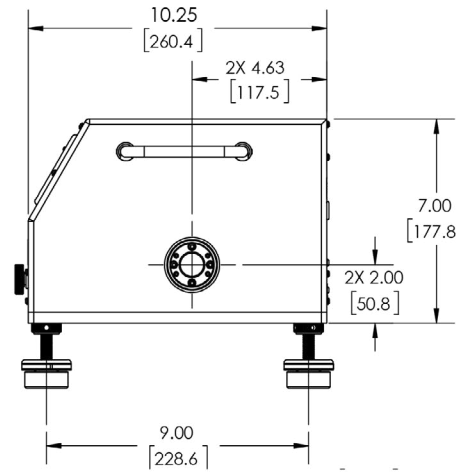
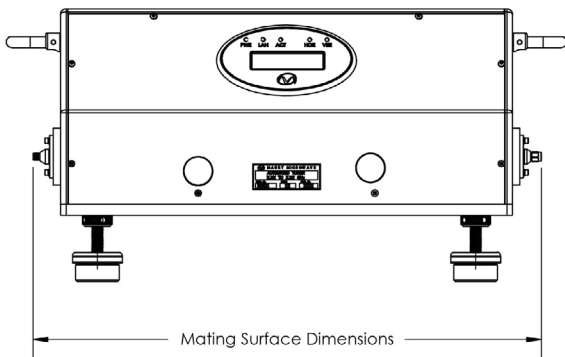

VISIT OUR WEB STORE  
TO LEARN MORE ABOUT  
OUR PRODUCTS

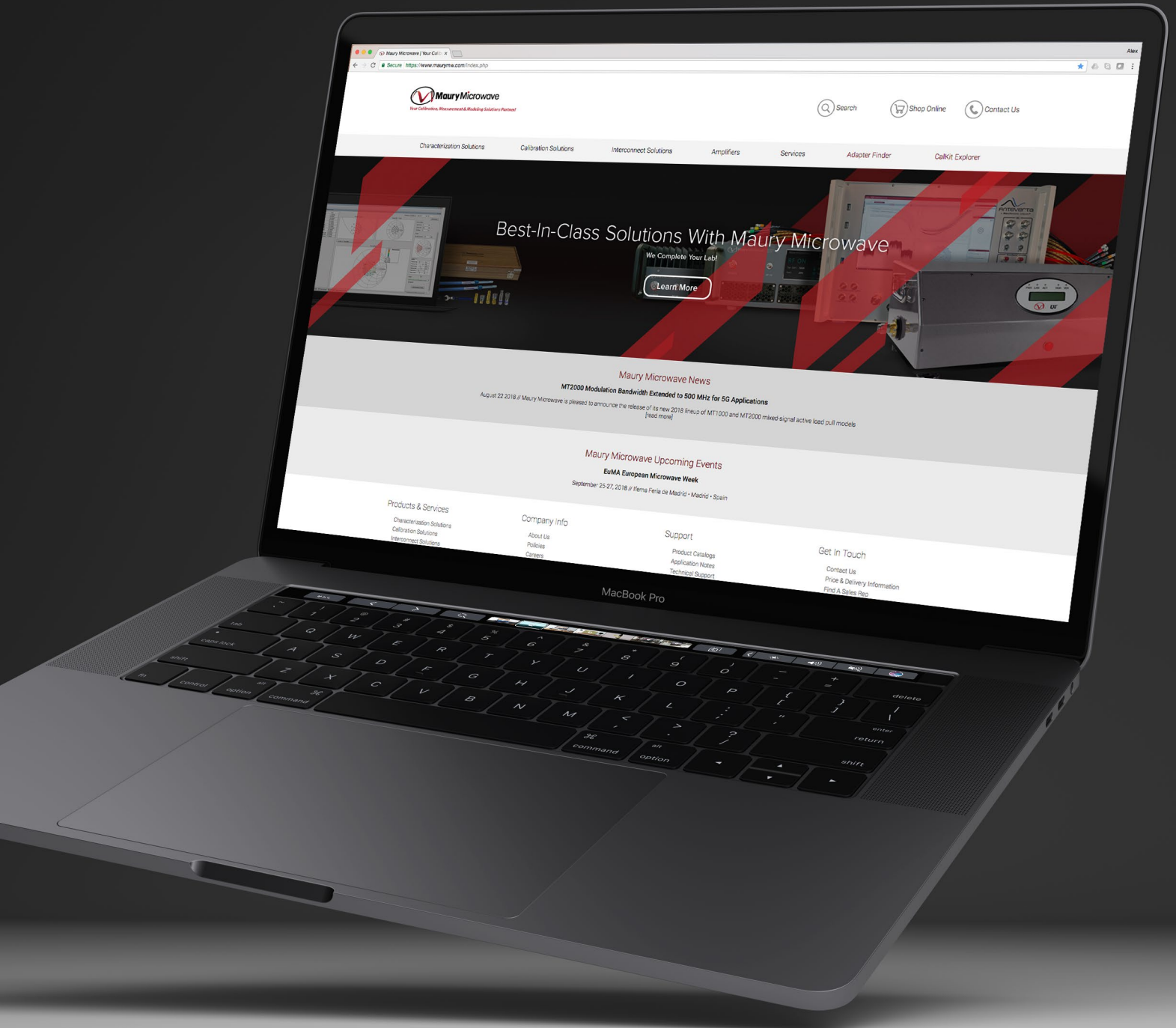

www.maurymw.com



**CONTACT US:**

W / [maurymw.com](http://maurymw.com)

E / [maury@maurymw.com](mailto:maury@maurymw.com)

P / +1-909-987-4715

F / +1-909-987-1112

2900 Inland Empire Blvd

Ontario, CA 91764

